

**GOLDEN CITY LODGE NO. 1 A.F. & A.M. 2011
STANDING COMMITTEES**

WELFARE

D. Hayman, WM (Chair)
L. Walker, SW
J. O'Brine, JW

FINANCE

J. O'Brine, JW (Chair)
R. Pitcock
D. Cooper

MEMORIAL FUNDS

J. O'Brine, SD (Chair)
C. Westerhoff
J. Arbuckle

POSTING

C. Westerhoff, SD (Chair)
J. O'Brine
M. Tims
R. Wenzel

GRIEVANCE

L. Walker, SW (Chair)
M. Smith
M. Mues

INVESTMENTS

R. Wenzel (Chair)-
-(2009-2011)
D. Hayman (2010-2012)
R. Pitcock (2011-2013)
L. McKean (non-voting)

2011 SPECIAL COMMITTEES

**SESQUICENTENNIAL
CELEBRATION**

D. Hayman (Chair)
B. Walker
B. House
N. Ramsey
B. Strotz
R. Wenzel
R. Franklin

FUNERALS

D. Hayman, WM (Chair)
L. Walker, SW
J. O'Brine, JW
B. Walker, Sec
J. Arbuckle, Tyler

**DIRECTOR'S OF THE
WORK**

M. Smith (Chair)
Sr. Line Officers
D. Cooper
M. Mues
B. Walker

MASONIC EDUCATION

M. Smith, (Chair)
Line officers

REFRESHMENTS

J. O'Brine, (Chair)
R. Franklin
W. Strotz

LIVING PAST MASTERS

Merritt E. Smith:1967	John A. McKenry III: 1996
Tommy R. Cook:1968	Craig R. Petty: 1997
Arthur R. Toney: 1974	E. Frederick Ernst: 1998
Gilbert A. Acevedo: 1975	M. John Bernstein: 1999
James K. Arbuckle: 1980	Richard A. Cook: 2000
Elmer E. King: 1981	Cliff Addenbrooke: 2001
Elbert F. Floyd: 1983	Byron G. Walker: 2002
Michael D. Mills:1984	Byron G. Walker: 2003
Timothy Johansson: 1985	Richard M. Wenzel: 2005
Wallace Techentien: 1988	David A. Cooper: 2006
Charles W. Robinson: 1989	Thomas E. Dunn: 2007
Ben H. Parker Jr.: 1990	Thomas E. Dunn: 2008
Marvin Lewis: 1994	Michael Tims: 2009
Willis S. Sample:1995	Richard M. Wenzel: 2010

LIVING PAST MASTERS OF OTHER LODGES

Howard Caldwell	Leonard Mohr
Wesley Campbell	Max Mues
Neil Colin	Charles Noah
Melvin D. Gullett	James Norris
Michael Halpin	Ronald Richards
Howard Hohnstein	Chris A. Westerhoff
John Hohnstein	
Lloyd McKean	

**GOLDEN MASONIC TEMPLE ASSOCIATION
BOARD OF DIRECTORS**

D. Cooper, President (303-929-5486) (2008-2012)
M.Tims, Vice President (303-932-1530) (Temple Scheduler)
mtmtt@msn.com (2010-2014)
M. Smith, Sec/Treasurer, (303-423-8016) (2009-2013)
R. Wenzel, (720-413-1790) (2011-2015)
Craig Petty, (303-902-2862) (2010-2011)

Temple Caretaker

Leonard Walker
720-448-5890
Temple Telephone (303) 279-9902

NON-PROFIT ORG
U.S. POSTAGE PAID
GOLDEN, COLO.
PERMIT No. 91

DATED MATERIAL

Golden City Lodge No. 1
A.F. & A.M.
400 Tenth Street
Golden, Colorado 80401

Return Service Requested

**Golden City Lodge
No. 1 A.F. & A.M.**



Chartered October 17, 1860

Masonic Temple Street Address
400 Tenth Street
Golden, Colorado

Masonic Temple Mailing Address
Golden City Lodge No. 1 A.F. & A. M.
400 Tenth Street
Golden, Colorado 80401

Masonic Temple Telephone Number:
(303) 279-9902

Please visit our web page:
<http://GoldenCityLodgeNo1.org>

Message of the Worshipful Master

Brethren,

My goal this month is to communicate to you all the financial state in which we find ourselves and the steps the lodge is taking to help ensure our ongoing stability.

Currently, our bylaws state that a yearly budget shall be created, approved and adopted by the Brethren. Any digression from the projected budget sets off a process whereby the Finance Committee evaluates our financial position and offers to the lodge an opinion, backed up by its intimate and current knowledge of our financial situation, and how the proposed digression affects the budget and our finances. When necessary, the Finance Committee solicits the opinion of the Investments Committee which is charged with the health and growth of our financial resources. This section of our bylaws outlines, not only a financial philosophy, but also a set of processes which when followed, should help our lodge make good and well educated financial decisions. What I find personally interesting is that this section of our bylaws has not been followed for so many years, that the vast majority of our Brethren have no idea what our resources are and how they are being handled. To that end, I instructed members of our lodge to begin the process of reconstructing our budgets and chart of accounts.

With a degree of hard work, a budget was created, passed to the brethren, voted on and adopted. In addition the Finances and Investment committees have renewed instructions regarding how to handle the flow of lodge money, and specifically, the flow of funds which do not fall into our projected budget. In order to help make this process as seamless and painless as possible, the Secretary, Treasurer and I have taken the lead in re-thinking/creating a usable chart of accounts for use in our more up to date accounting system.

With all of this recent history in mind, it is important to know that while we do have a certain amount of monetary reserves, with the Market in the state it is in, *we are deficit spending*, just to keep things chugging along with the status quo. If this activity keeps up on its current track, it will not be long before we have no more lodge building in which to meet.

To this end, I recently created two additional committees, chaired by strong and knowledgeable Brothers. These committees are:

- “Ways and Means” Committee—a committee charged with offering reachable ways by which we might generate additional income (means) to help offset our spending deficit. Under consideration are everything from fundraising activities to dues raising.
- “Motivation” Committee—a committee charged with finding more ways with which we can motivate our brethren to take part in activities beyond our bi-monthly meetings.

It is my hope that these committees bring fourth new and exciting ideas which with strengthen our lodge and brotherhood, not just for now, but also for future generations. Interestingly, these efforts coincide well with the words of wisdom offered last night by our Deputy Grand Master. In essence what he said was that we are ALL on the level, from the newly initiated Entered Apprentice to the Most Worshipful Grand Master. One of the messages I took from this is that with new blood comes new ideas, new approaches and in general a different way of looking at things. All too often, new Masons are either intimidated or in some cases discouraged from sharing their thoughts in open lodge. Over time, new Masons, become lodge leaders in one way or another and it is very easy to dismiss this valuable resource. With that in mind, I would ask each of you to consider that new ideas may well be different ideas. However, different ideas are not automatically bad ideas and should be well considered before and without automatic dismissal. In my mind, there is a lot of space within our circle, and it becomes our duty as a lodge to balance new ideas with existing rules, laws and traditions, while at the same time offering encouragement.

In terms of this, I encourage all of you to help, *participate and support* these committees, hardworking individuals, and indeed the lodge itself. Do not be shy! If you do not understand what is being discussed or why, please stand up ask for clarity. If you have something to add, a question to ask, a comment to make, I cannot encourage all of you more strongly, to do so. This is YOUR lodge—we work for and with each other, from the ground up. YOU are the cornerstone.

Fraternally,
Daniel S. Hayman, Worshipful Master

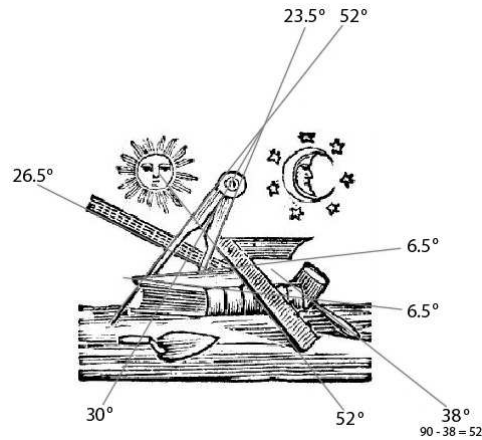

**GOLDEN CITY LODGE
NO. 1 A.F. & A.M.**

April 2011

Monday, April 4, 2011

Golden Masonic Temple

6:00 PM Fellowship Dinner

7:00 PM 3187rd Stated Communication and
Presentation on John Shivington

Monday, April 18, 2011

Golden Masonic Temple

5:30 PM Light Snacks

6:00 PM EA Degree Work Commences

7:00 PM, 3188th Stated Communication
EA Degree Work

REMINDERS:

Youth Groups

Bethel No. 43 Job’s Daughters
2nd & 4th Mondays, 7:00 PM

Golden Chapter Order of DeMolay
1st and 3rd Wednesday, 7:00 PM

Pancake Breakfast

4th Sunday of every month,
8:00 AM to 11:00 AM,

hosted by Mount Zion Chapter No. 133,
Order of the Eastern Star

Contacts

To contact Golden City Lodge No. 1 AF&AM, Mt. Zion Chapter # 133 OES; Golden Chapter #5 RAM, Jefferson Council #24 R&SM, Jefferson Highlands Commandry #30, Friendship Court #7 Amaranth, Job’s Daughters, Rainbow for Girls, DeMolay – leave a message at 303-279-9902. Shrine Hospital or Burn Center for Children 1-800-237-5055, Scottish Rite Child Language Disorders Foundation 866-289-6797, Robert Russell Eastern Star Masonic Center and Village 303-756-9489

Brethren standing on any degree are always welcome.

Any Brother who needs a ride to lodge, please call the Worshipful Master at; 303-838-1725, or the Secretary at 303-278-7362

Fees for the degrees are \$100 (\$50 EA, \$30 FC, \$20 MM). Annual dues are \$35 plus per capita (\$42 in 2011).

**GOLDEN CITY LODGE NO. 1, A.F. & A.M.
2010 OFFICERS**

WORSHIPFUL MASTER

Dan Hayman (Sue)303-838-1725
Dan.Hayman@Accomplishments.com.....Cell: 303-638-6381

SENIOR WARDEN

Leonard L. Walker720-448-5890

JUNIOR WARDEN

John O’Brine (Nancy)303-467-6825

TREASURER

Lloyd L. McKean (Marion)303-424-3021

SECRETARY

Byron G. Walker...303-278-7362
127 Burgess Ave., Golden 80401GoldenCityLodge@q.com

SENIOR DEACON

Christopher Westerhoff (Nancy)303-431-2204

JUNIOR DEACON

Neil Ramsey (Cathy) 303-279-2059
Cell: 303-995-7745

SENIOR STEWARD

Ricky Franklin (Aundrea) 720-348-0507

JUNIOR STEWARD

William Strotz (Kimberly)303-274-2541

CHAPLAIN

Melvin Gullett (Edith)720-536-8605

MARSHALL

Charles Noah (Jane).....303-733-2283

TYLER

James Arbuckle (Judy)...303-278-1077

DISTRICT LECTURER

Robert Heath303-431-1521